

# Product data sheet

## Characteristics

# 9070T100D52

Transformer, Type T, industrial control, 100 VA,  
380/400/415 VAC primary / 12/24 VAC second, 1  
phase, 50/60 Hz, 55 °C



Product availability: Non-Stock - Not normally stocked in distribution facility

Price\*: 554.00 USD

### Main

Product or Component Type	Industrial Control Transformer
Rated power in VA	100 VA

### Complementary

Phase	1 phase
Rated power in VA	100 VA

### Environment

NEMA Degree of Protection	Not rated (open device)
---------------------------	-------------------------

### Ordering and shipping details

Category	16201 - 9070 T (NOT TF) 250-2000VA
Discount Schedule	CP8
GTIN	00785901712053
Nbr. of units in pkg.	1
Package weight(Lbs)	3.90 Lb(US) (1.769 kg)
Returnability	No
Country of origin	US

### Packing Units

Unit Type of Package 1	PCE
Package 1 Height	3.50 In (8.89 cm)
Package 1 width	3.88 In (9.855 cm)
Package 1 Length	4.00 In (10.16 cm)

### Offer Sustainability

Sustainable offer status	Green Premium product
California proposition 65	WARNING: This product can expose you to chemicals including: Phenyl glycidyl ether, which is known to the State of California to cause cancer and birth defects or other reproductive harm. For more information go to <a href="http://www.P65Warnings.ca.gov">www.P65Warnings.ca.gov</a>
REACH Regulation	<a href="#">REACH Declaration</a>
EU RoHS Directive	Compliant <a href="#">EU RoHS Declaration</a>
Mercury free	Yes
RoHS exemption information	<a href="#">Yes</a>
China RoHS Regulation	<a href="#">China RoHS Declaration</a>
Environmental Disclosure	<a href="#">Product Environmental Profile</a>
PVC free	Yes

Contractual warranty

---

Warranty	18 months
----------	-----------

---

Approximate Dimensions

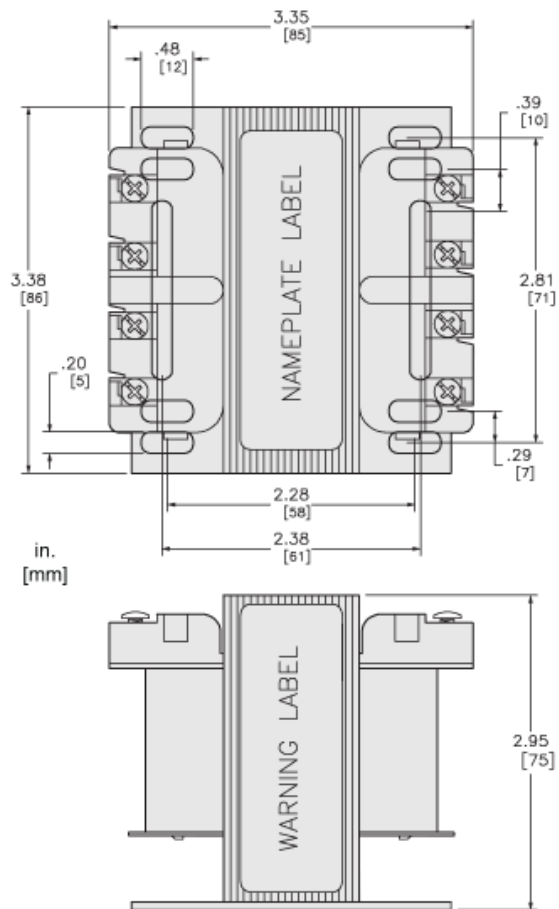

Product Life Status : Commercialised